

Bronze High Lift Safety Relief Valve



LV 1500

Screwed BSPP, PTFE Seat, Cap Top with Test Lever. Certified and Calibrated on request.



Pressure / Temperature Specifications

Pressure	1.0 Bar to 12.5 Bar (½" to 1")
	0.4 Bar to 12.5 Bar (¼" to 3")
Temperature	-20°C to 195°C

Dimensions

I	O	A	B	C	Kg
½"	¾"	33	20	120	0.53
¾"	1"	39	24	132	0.76
1"	1¼"	45	30	155	1.35
1¼"	1½"	54	36	201	2.35
1½"	2"	64	41	241	4.2
2"	2½"	76	47	267	6.8
2½"	3"	90	60	330	12.5

Material Specifications

1. Thrust Washer	CW609N Brass
2. Grub Screw	Steel
3. Test Lever	CC754S Brass
4. Spring	Chrome Vanadium Alloy
5. Label	Yellow Kapton®
6. Spring Cover	Bronze
7. Piston	CW609N Brass
8. Diaphragm	Silicone Rubber
9. Seat Seal Holder	CC491K Brass
10. Seat Seal	PTFE
11. Starlock Washer	Stainless Steel
12. Body	CC491K Brass
13. Lever Pin	Steel
14.* Lead Seal	Lead
15. Adjusting Screw	CW609N Brass
16. Spring Plate	CW609N Brass
17. Spindle	CW721R Spindle
18. Seat Seal Retaining Plate	CC491K Bronze
19. O-ring	Viton

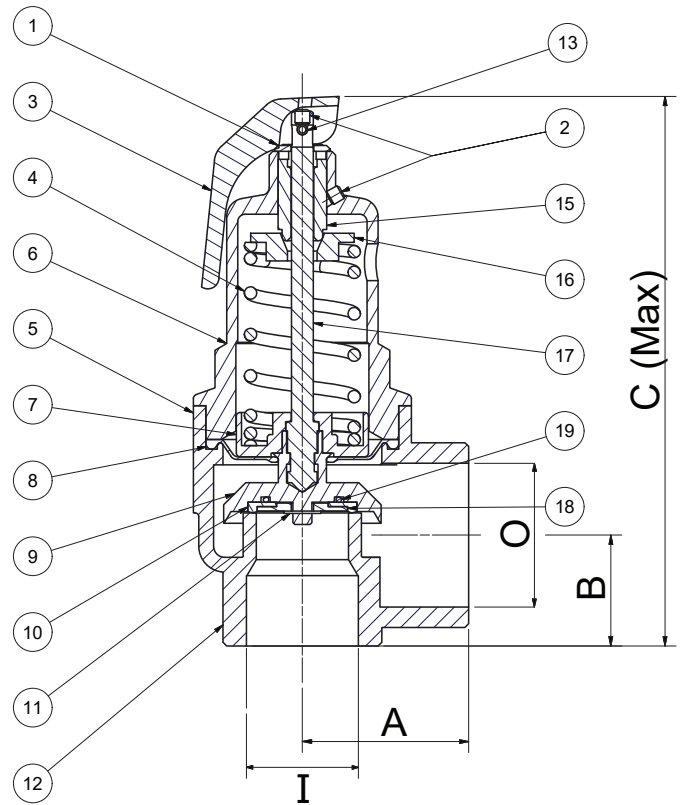

Continues on Page 2

Bronze High Lift Safety Relief Valve



LV 1500

Discharge Capabilities

The discharge capacity of a safety valve must be equal to or greater than the output of the boiler or system it is protecting. To ensure that the correct method of sizing is used, reference should be made to the relevant BS specification for the design of the boiler or system. Fig 500 capacities are tabulated below to assist selection.

AIR CAPACITY - 10% OVERPRESSURE (BS EN 4126-1)								
SET PRESSURE BAR	std. litres/sec (Kdr=0.479)							
	DN10	DN15	DN20	DN25	DN32	DN40	DN50	DN65
1.0	18	34	61	95	156	244	381	644
2.0	28	52	93	145	238	372	581	982
3.0	38	70	125	195	320	500	780	1319
4.0	47	88	157	245	401	628	980	1656
6.0	67	124	221	345	565	883	1379	2331
8.0	86	160	284	445	728	1139	1778	3006
10.0	105	196	348	545	892	1394	2178	3681
12.5	130	241	428	670	1096	1714	2677	4524

To convert to ft³/min multiply by 2.1.

STEAM - 10% OVERPRESSURE (BS 6759)								
SET PRESSURE BAR	Kg/hr (Kdr=0.479)							
	*DN10	*DN15	DN20	DN25	DN32	DN40	DN50	DN65
1.0	50	93	166	259	425	664	1037	1752
2.0	76	142	253	395	647	1012	1580	2670
3.0	103	191	340	531	869	1359	2123	3588
4.0	129	240	427	667	1092	1707	2666	4506
6.0	182	338	600	938	1537	2402	3752	6341
8.0	234	436	774	1210	1981	3098	4838	8177
10.0	287	534	948	1482	2426	3793	5924	10013
12.5	352	657	1165	1821	2982	4663	7281	12307

To convert to lb/hr multiply by 2.2.

* The minimum bore size permitted by BS specifications for steam and hot water boilers is 20mm.

Capacities given for the smaller sizes in the tables, are for applications outside the scope of these standards.

HOT WATER - UNVENTED SYSTEM - 10% OVERPRESSURE (BS EN 4126-1)								
SET PRESSURE BAR	kW (Kdr=0.479)							
	* DN10	* DN15	DN20	DN25	DN32	DN40	DN50	DN65
1.0	31	59	104	162	266	416	650	1098
2.0	48	89	158	248	405	634	990	1673
3.0	64	120	213	333	545	852	1330	2248
4.0	81	151	267	418	684	1070	1670	2824
6.0	114	212	376	588	963	1505	2351	3974
8.0	147	273	485	758	1242	1941	3032	5124
10.0	180	335	594	929	1520	2377	3712	6275
12.5	221	411	730	1141	1869	2922	4563	7713

To convert to Btu/hr multiply by 3,400

The capacities tabulated are for unvented (pressurised or sealed) heating systems.

For vented systems we generally recommend the use of Fig 542 Safety Relief Valves.

Fig 500 Safety Valves can be used for high output systems where its greater discharge capacity is advantageous.

For unvented hot water supply systems, Fig 500T Combined Pressure & Temperature Relief Valves should be used.

WATER - UNVENTED SYSTEM - 10% OVERPRESSURE (BS EN 4126-1)								
SET PRESSURE BAR	kg/min water (Kdr=0.479)							
	DN10	DN15	DN20	DN25	DN32	DN40	DN50	DN65
1.0	40	75	134	209	343	536	837	1414
2.0	57	107	189	296	485	758	1183	2000
3.0	70	131	232	363	594	928	1449	2450
4.0	81	151	268	419	685	1072	1674	2829
6.0	99	185	328	513	840	1313	2050	3465
8.0	115	213	379	592	969	1516	2367	4001
10.0	128	239	423	662	1084	1695	2646	4473
12.5	143	267	473	740	1212	1895	2959	5001

In the above tables, discharge capacities have been calculated in accordance with BS EN 4126-1 & BS 6759, using a derated coefficient of discharge (Kdr) 0.479, approved by AOTC