

Foot Valve & Strainer

LV 5180

Flanged PN10, Cast Iron Body, Stainless Steel Screen, Cast Iron Disc



Pressure/Temperature Specifications

Pressure	PN10
Cracking Pressure	0.1 Bar
Temperature	-10°C to 80°C

Material Specifications

1. Body	EN GJL 250 5.1301 Cast Iron
2. Guide	EN GJL 250 5.1306 Cast Iron
3. Closing Assembly	EN GJL 250 5.1306 Cast Iron
4. Gasket	EPDM
5. Spring	AISI 302 Stainless Steel
6. Hex Bolt	A2 Steel
7. Enlarged Washer	A2 Steel
8. Hex Nut	A2 Steel
9. Screen	AISI 302 Stainless Steel

Dimensions

Size	DS	HS	D1	H	KS	Kvs	Kg
2"	156	80	111	180	129	99	5.7
2½"	176	100	131	220	149	145	8.8
3"	192	120	148	260	164	258	10.3
4"	212	150	168	320	184	360	14.0
5"	242	175	198	375	214	516	22.0
6"	275	200	222	430	244	620	31.5
8"	332	250	278	550	304	985	50.0
10"	385	300	329	670	356	1620	78.0
12"	445	350	384	760	413	2365	107.0

Dimensions

Size	D	K	n x d
2"	165	125	4 x 19
2½"	185	145	4 x 19
3"	200	160	8 x 19
4"	220	180	8 x 19
5"	250	210	8 x 19
6"	285	240	8 x 23
8"	340	295	8 x 23
10"	395	350	12 x 23
12"	445	400	12 x 23

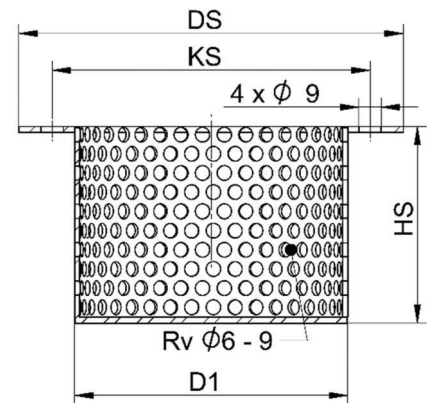
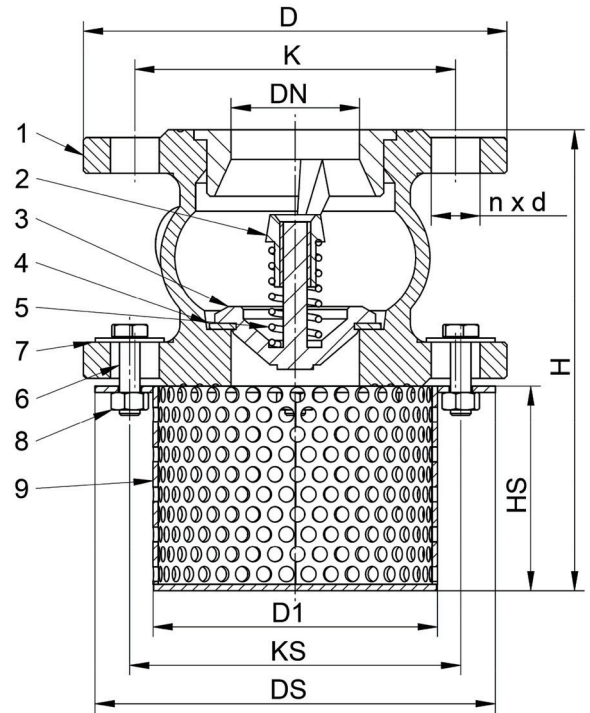

Foot Valve & Strainer

LV 5180

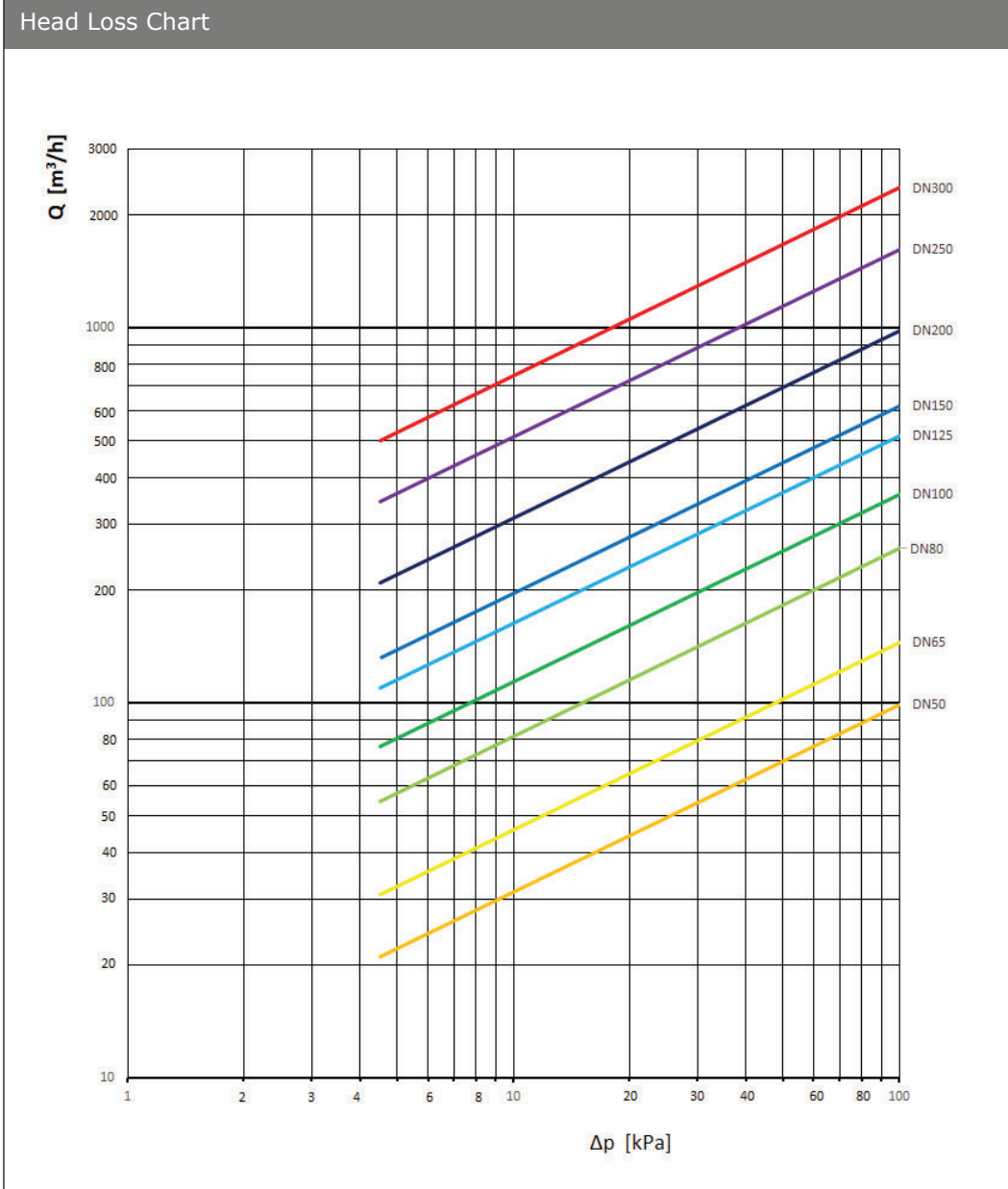

Last updated 11/06/2025