

Cast Steel Globe Valve – ANSI 300

Flanged to ANSI 300RF, Design to API600,
O S & Y, Bolted Bonnet, A216 Gr WCB, Trim
13% CR + HFS.

Class 300 Rated
Temperature -29°C to 538°C

Material List

No.	Parts	Materials
1	Body	ASTM A216 Gr WCB
2	Seat Rings	Stellite Gr 6 Faced
3	Disc	ASTM A216 Gr WCB + 13 Cr Faced
4	Disc Thrust Plate	ASTM A276 Type 420
5	Disc Nut	ASTM A276 Type 410
6	Stem	ASTM A182 F6a
7	Bonnet Bolt Nuts	ASTM A194 Gr 2H(M)
8	Bonnet Bolts	ASTM A193 Gr B7(M)
9	Gasket	Stainless Steel + Graphite
10	Backseat Bushing	ASTM A276 Type 410
11	Stem Packing	Braided Graphite & Die Formed Graphite Ring
12	Bonnet	ASTM A216 Gr WCB
13	Eye Bolt Pins	Carbon Steel
14	Gland	ASTM A276 Type 410
15	Gland Flange	ASTM A216 Gr WCB
16	Gland Eye Bolts	ASTM A193 Gr B7(M)
17	Eye Bolt Nuts	ASTM A194 Gr 2H(M)
18	Stem Nut	ASTM A439 Gr D-2 / ASTM B148 9A
19	Screw	Carbon Steel
20	Handwheel	Steel
21	Handwheel Nut	ASTM A194 Gr 2H(M)
22	Washer	Carbon Steel
23	Yoke	ASTM A216 Gr WCB
24	Yoke Pan Bolt Nuts	ASTM A194 Gr 2H(M)
25	Yoke Pan Bolts	ASTM A193 Gr B7(M)
26	Bearing	Steel
27	Lantern Ring	ASTM A276 Type 410

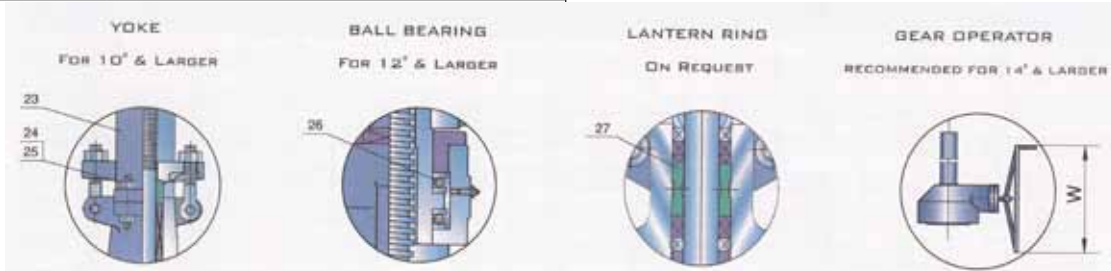
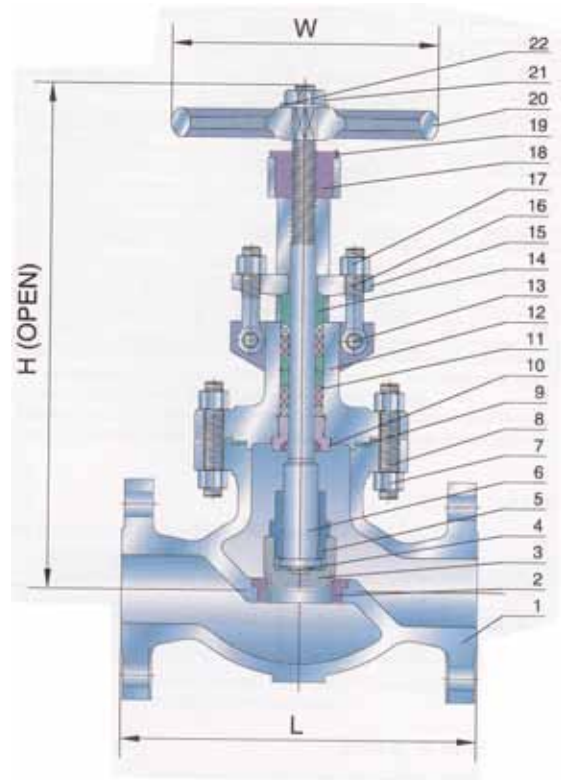

Continued on next page

Carbon Steel Globe Valve – ANSI 300

Dimensions

Size	L	H (Open)	W	Kg
2"	267	385	200	28
2½"	292	420	250	36
3"	318	440	250	50
4"	356	525	350	75
6"	445	650	400	165
8"	559	900	550	275
10"	622	950	600	400
12"	711	1030	700	640
14"	838	1200	800	780
16"	914	1375	800	1150

