

# Carbon Steel Ball Valve - ISO Top - TFM 1600 Seats



LV8453 Socket Weld, LV 8455 BSPP & LV8457 NPT

ISO 5211 for Direct Mount, 3 Piece WCB Carbon Steel Body, Full Bore, CF8 Stainless Steel Ball, 304 Stainless Steel Stem, **TFM 1600** Seats, Firesafe Certified, Locking Lever



Pressure / Temperature Specifications	
Pressure	PN130 1/4" to 1"
	PN100 1 1/4" to 2"
	PN130 2 1/2" & 3"
	PN63 4"
Temperature	-10°C to 200°C

Material Specifications	
1. Body	WCB Carbon Steel
2. End Cap	WCB Carbon Steel
3. Joint Gasket	Graphite
4. Ball	CF8 Stainless Steel
5. Seat	TFM 1600
6. Stem	AISI 304 Stainless Steel
7. Thrust Washer	25% Carbon
8. O-ring	Viton
9. Stem Packing	Graphite
10. Stem O-ring	AISI 304 Stainless Steel
11. Belleville Washer	AISI 301 Stainless Steel
12. Stem Nut	AISI 304 Stainless Steel
13. Saddle Washer	AISI 304 Stainless Steel
14. Hex Bolt	AISI 304 Stainless Steel
15. Stop Pin	AISI 304 Stainless Steel
16. Handle	AISI 304 Stainless Steel
17. Handle Nut	AISI 304 Stainless Steel
18. Locking Device	AISI 304 Stainless Steel
19. Handle Cover	PVC
20. Square Washer	AISI 304 Stainless Steel

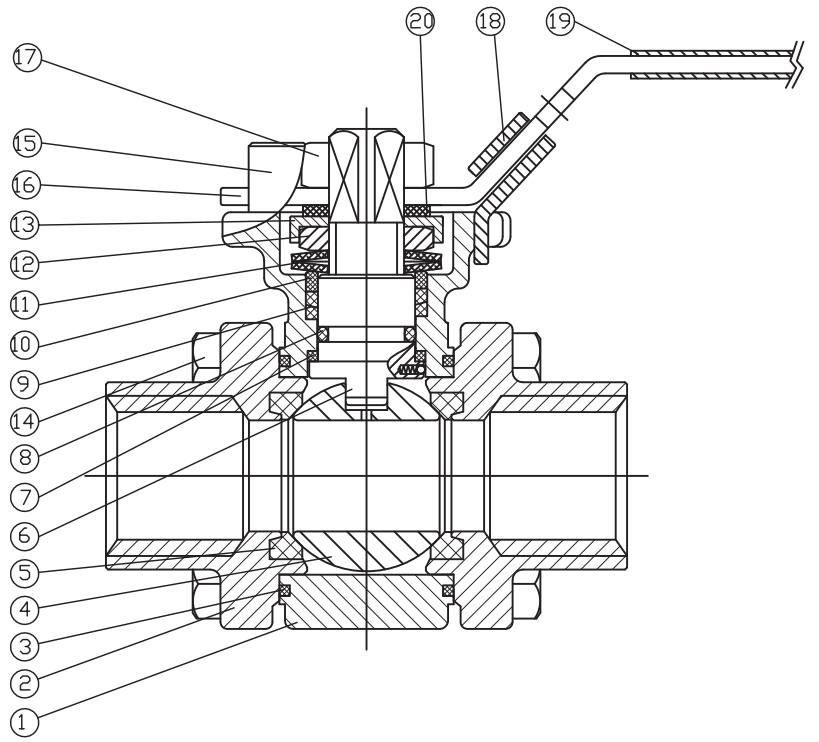

Flow Rate & Torque Figures		
Size	CV	Nm
1/4"	6.4	4.8
3/8"	7.9	4.8
1/2"	11.2	7.4
3/4"	21.0	13.7
1"	34.0	20.0
1 1/4"	57.0	27.0
1 1/2"	80.0	35.0
2"	148.0	50.0
2 1/2"	265.0	70.0
3"	415.0	90.0
4"	780.0	120.0

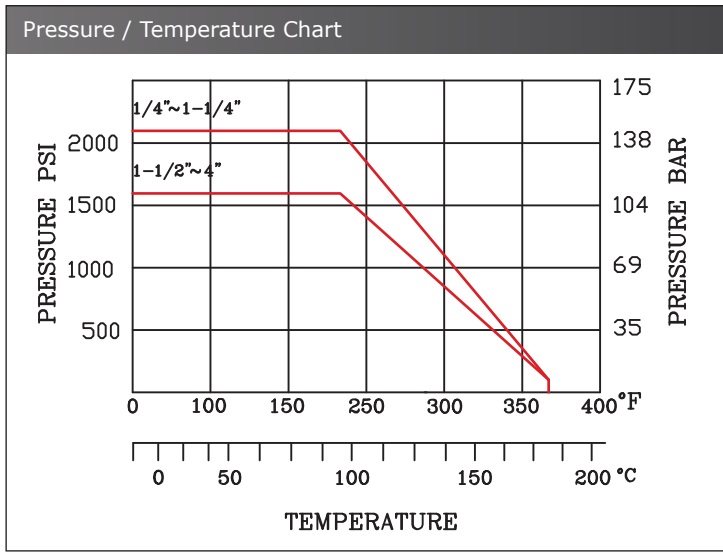

See following page for dimensions

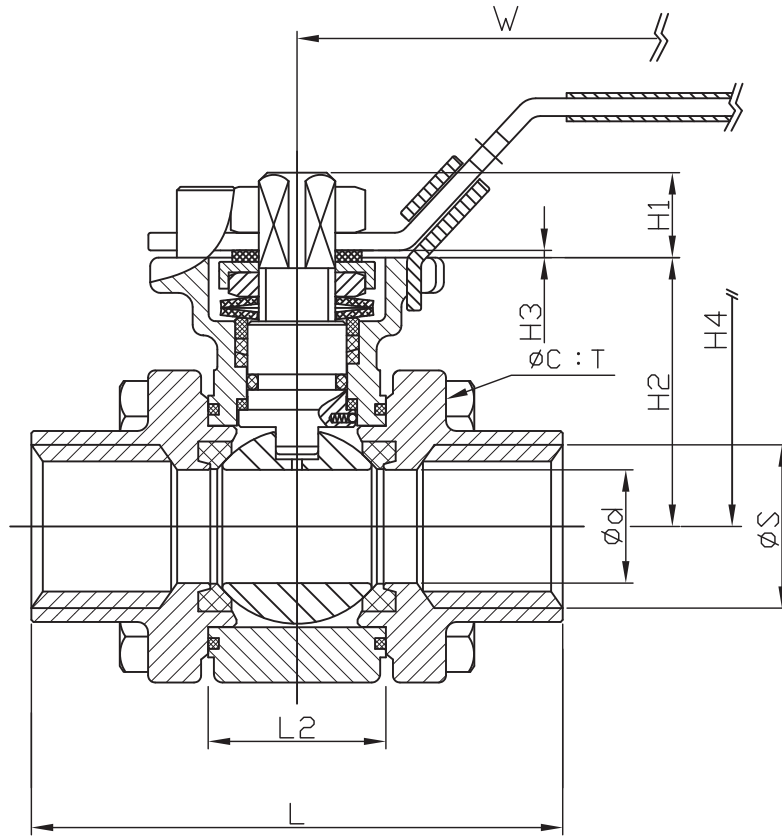

Dimensions												
Size	Ød	L	L2	H1	H2	H3	H4	ØS*	ØC	T	W	Kg
1/4"	11	65	22.7	11	34	1 to 5	68	14.1	6.5	M6	117	0.52
3/8"	12.7	65	22.7	11	34	1 to 5	68	17.6	6.5	M6	117	0.55
1/2"	16	75	24	11	38	1 to 5	72	21.7	6.5	M6	117	0.64
3/4"	20	80	28	14	43	1 to 5	79	27.1	8.4	M8	127	0.95
1"	25	90	34	12	50	1 to 5	85	33.8	8.4	M8	170	1.34
1 1/4"	32	110	44	12	55	1 to 5	88	44.0	10.6	M10	170	2.25
1 1/2"	38	120	53	16	65	1 to 5	105	50.0	10.6	M10	182	3.63
2"	50	140	65	16	75	1 to 5	114	61.5	10.6	M10	182	5.97
2 1/2"	65	185	74.6	28	103	1 to 5	153	76.9	12.6	M12	333	11.0
3"	80	205	87	28	113	1 to 5	165	89.8	12.6	M12	333	14.2
4"	100	240	112.5	40	150	1 to 5	205	115.4	14.6	M14	333	28.0

\* Relevant to socket weld version only

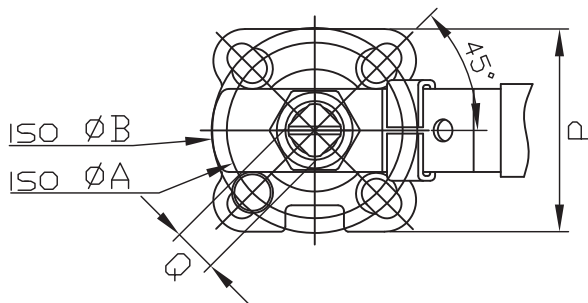

Dimensions				
Size	ISO ØA	ISO ØB	Q	P
1/4"	F03	F03	9	36
3/8"	F03	F03	9	36
1/2"	F03	F04	9	41.5
3/4"	F03	F04	11	41.5
1"	F04	F05	11	50.4
1 1/4"	F04	F05	11	50.4
1 1/2"	F05	F07	14	66.5
2"	F05	F07	14	66.5
2 1/2"	F07	F10	17	90
3"	F07	F10	17	90
4"	F10	F12	22	113