

Carbon Steel 3 Way Ball Valve - ISO Top



LV 8503 T Port & LV 8513 L Port

ISO 5211 for Direct Mount, Flanged **PN16**, 3 Piece WCB Carbon Steel Body,
Full Bore, L or T Port, CF8 Stainless Steel Ball, 304 Stainless Steel Stem,
TFM 1600 Seats

Pressure / Temperature Specifications	
Pressure	PN16
Temperature	-10°C to 180°C

Material Specifications 1/2" to 1"	
1. Body	WCB Carbon Steel
2. Cap	WCB Carbon Steel
3. Ball	304 Stainless Steel
4. Seat	TFM1600
5. Stem	304 Stainless Steel
6. Gasket	TFM1600
7. Thrust Washer	TFM1600
8. O-ring	Viton
9. Packing	TFM1600
10. Gland	304 Stainless Steel
11. Spring Washer	301 Stainless Steel
12. Stem Nut	304 Stainless Steel
13. Belleville Washer	304 Stainless Steel
14. Handle Washer	304 Stainless Steel
15. Locking Device	304 Stainless Steel
16. Handle	304 Stainless Steel
17. Handle Cover	Plastic
18. Cap A	WCB Carbon Steel
19. Bolt	304 Stainless Steel
20. Stop Pin	304 Stainless Steel
21. Bolt	304 Stainless Steel
22. Nut	304 Stainless Steel

Dimensions 1/2" to 1"			
DN	1/2"	3/4"	1"
d	15	20	25
D	95	105	115
C	65	75	85
G	45	58	68
T	16	18	18
f	2	2	2
N	4	4	4
M	14	14	14
L	160	165	180
H	80	84	96
W	123	123	153
ISO	F03-04	F03-04	F04-05
E	36-42	36-42	42-50
H1	9	9	11
W1	9	9	11
Ra	R3	R3	R3
Rb	R3	R3	R3.5
Kg (L)	4.7	6.2	9.4
Kg (T)	4.6	6.2	9.3

Torque (Nm)	
Size	Nm
1/2"	37.0
3/4"	37.0
1"	55.0
1 1/2"	80.0
2"	110.0
2 1/2"	170.0
3"	210.0
4"	270.0
6"	400.0

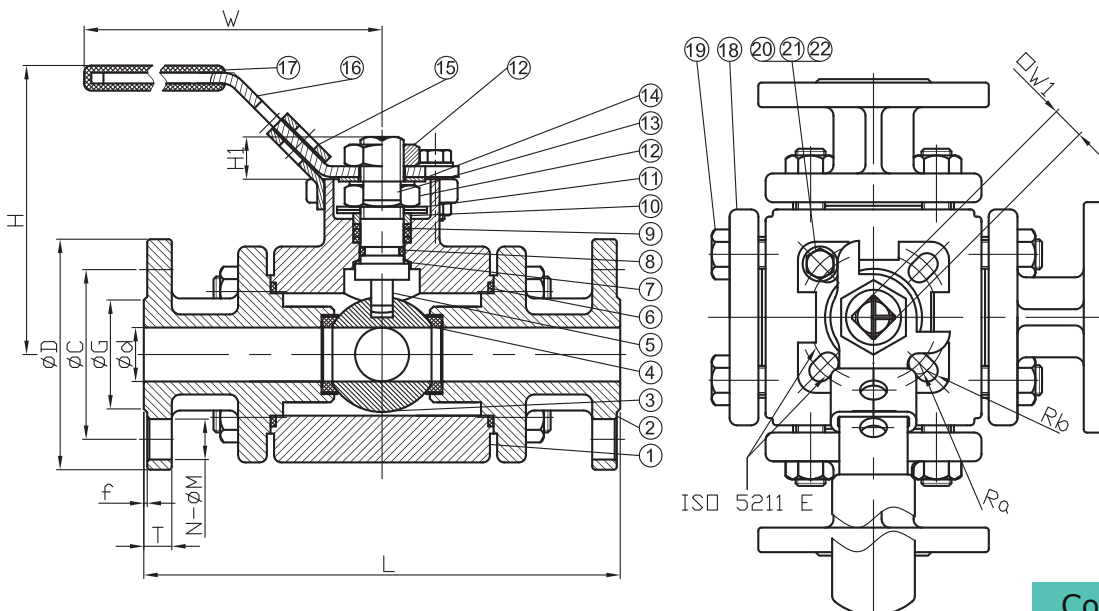

Continues on Page 2

Carbon Steel 3 Way Ball Valve - ISO Top



LV 8503 T Port & LV 8513 L Port

Material Specifications 1 1/2" to 6"	
1. Body	WCB Carbon Steel
2. Cap	WCB Carbon Steel
3. Ball/Stem	304 Stainless Steel
4. Seat	TFM1600
5. Gasket	TFM1600
6. O-ring	Viton
7. Gasket	TFM1600
8. Packing	TFM1600
9. Gland	304 Stainless Steel
10. Spring Washer	301 Stainless Steel
11. Cap C	WCB Carbon Steel
12. Handle Head	304 Stainless Steel
13. Handle Cover	Plastic
14. Handle Pole	Galvanized Steel
15. Handle Bolt	304 Stainless Steel
16. Sleeve	PTFE
17. Cap B Bolt	304 Stainless Steel
18. Cap B	WCB Carbon Steel
19. Bolt	304 Stainless Steel
20. Stop Pin	304 Stainless Steel
21. Cap A Bolt	304 Stainless Steel
22. Cap A	WCB Carbon Steel

Dimensions 1 1/2" to 6"						
DN	1 1/2"	2"	2 1/2"	3"	4"	6"
d	40	50	65	76	96	148
D	150	165	185	200	220	285
C	110	125	145	160	180	240
G	88	102	122	138	158	212
T	18	20	18	20	20	22
f	3	3	3	3	3	3
N	4	4	4	8	8	8
M	18	18	18	18	18	22
L	234	273	300	305	369	480
H	171	176	208	216	236	329
W	403	403	504	504	504	800
ISO	F07	F07	F10	F10	F10	F14
E	70	70	102	102	102	140
H1	19	19	24	24	24	38
W1	17	17	22	22	22	36
ØMa	10	10	12	12	12	18
Kg (L)	16.9	20.1	28.2	36.2	63.3	148.9
Kg (T)	16.5	19.9	27.5	35.4	59.2	144.9

